

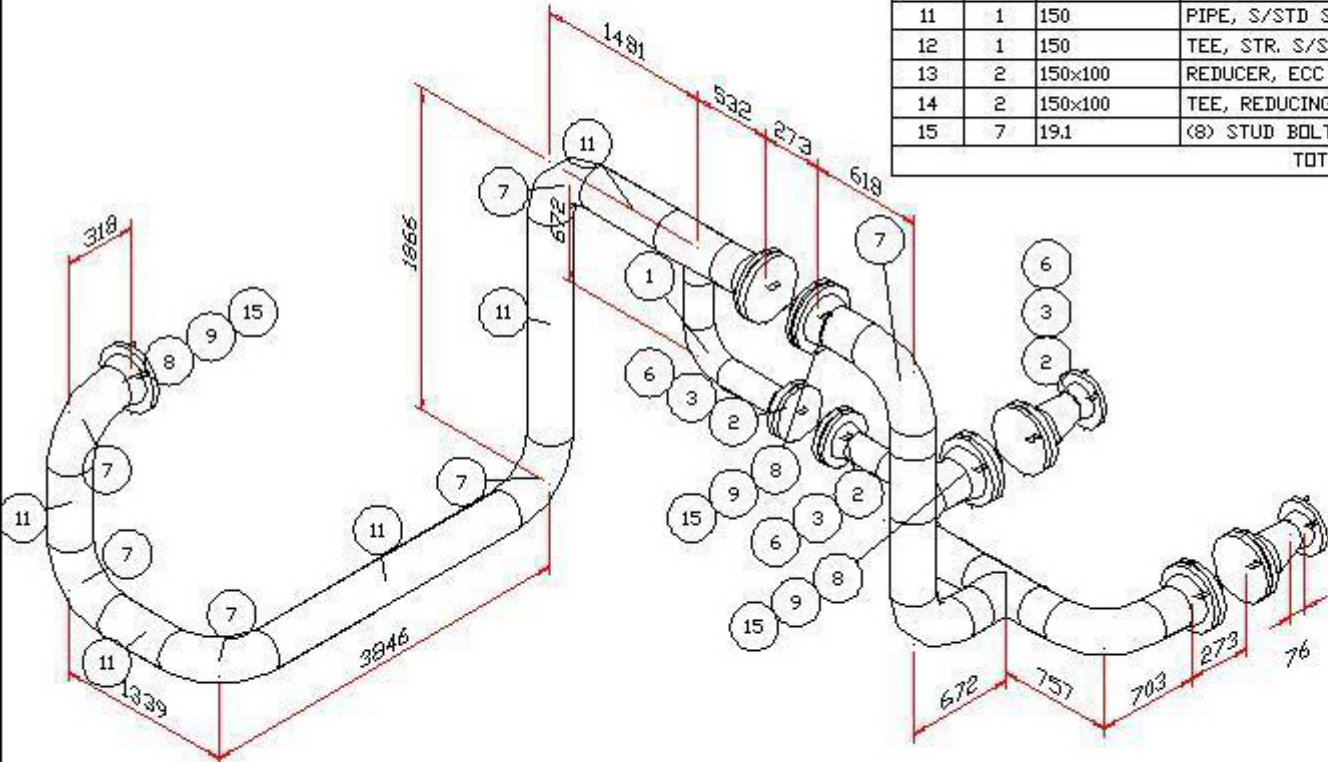

BILL OF MATERIAL

MARK	QTY	ALPHA_SIZE	DESCRIPTION	LENGTH	WEIGHT
1	1	100	ELL, 90° LR S/STD, ASTM A-234 GR WPB		3.95
2	4	100	FLG, RFWN 150LB S/STD BORE, ASTM A-105		27.20
3	4	100	GASKET, 3MM THK, 150LB		4.00
4	1	100	GATE VALVE, 150LB FLG	229	49.89
5	1	100	PIPE, S/STD SMLS, ASTM A-106 GR B	1141	18.33
6	4	15.9	(8) STUD BOLTS W/ NUTS	89	4.00
7	9	150	ELL, 90° LR S/STD, ASTM A-234 GR WPB		93.06
8	7	150	FLG, RFWN 150LB S/STD BORE, ASTM A-105		76.23
9	7	150	GASKET, 3MM THK, 150LB		7.00
10	3	150	GATE VALVE, 150LB FLG	267	238.14
11	1	150	PIPE, S/STD SMLS, ASTM A-106 GR B	10675	301.35
12	1	150	TEE, STR. S/STD, ASTM A-234 GR WPB		14.20
13	2	150x100	REDUCER, ECC S/STD, ASTM A-234 GR WPB		7.34
14	2	150x100	TEE, REDUCING S/STD, ASTM A-234 GR WPB		25.04
15	7	19.1	(8) STUD BOLTS W/ NUTS	95	7.00
TOTAL WEIGHT:					876.72



MATERIAL	A-106 GR B	TAG	001-A23
SPEC.	150_MM	DWG REF.	Pipe Run.dwg
SCH.	STD	LINE SIZE	150
RATING	150	WELD PROC.	WPC-101
TEMP.	245 F	INSULATION	2-CAL
PRESS.	210 PSI	REMARKS	NONE



ENG. RECORD	DATE
DRAWN BY CHRISB	06/27/08
CHECKED	
APPROVED	
APPROVED	
SCALE	NONE

COADE	
LINE NO.	150-PRD-550-150_MM
JOB NO.	1099
DRAWING NO.	1099-97-0
REV.	0

NO.	REVISION	DATE	BY	APR